



Canadian National Championship Regatta

Sudbury Yacht Club

Sudbury Ontario

18-19 July 2026

SAILING INSTRUCTIONS

The Organizing Authority for this regatta is the Canadian Y-Flyer Yacht Racing Association in conjunction with the Sudbury Yacht Club.

RULES: The regatta will be governed by the Racing Rules of Sailing 2025-2028. Except as noted below:

62.1(a) - The scoring of finish by the race committee shall not be subject of protest.

32.2 - See procedure for shortening course below.

63.7 -The sailing instructions shall take precedence in the event of conflict between the RRS and the sailing instructions.

ENTRY: Competitors declared eligible by the CYFYRA may enter boats by completing the registration form with the organizing committee.

NOTICES TO COMPETITORS: Notices to competitors will be posted ashore prior to each day's commencement of racing. Notices will be available ashore, if required, at the conclusion of the day's sailing.

CHANGES TO THE SAILING INSTRUCTIONS:

SIGNALS MADE ASHORE:

- Signals made ashore will be displayed from the RC Boat flag staff.
- When Code Flag "AP" is made ashore with 2 sounds, further racing is postponed until the next Harbor Signal is made. The next Harbor Signal will not be made for at least 30 minutes after Code Flag AP is displayed ashore. This changes RRS Race Signals.
- The departure of the RC Boat from its mooring, with one sound signal, is the Harbor Signal. Competitors should proceed to the racing area. If racing has been postponed ashore with the display of Code Flag AP, the Harbor Signal ends the postponement. The next Warning Signal will be no sooner than 20 minutes after the Harbor Signal.

SCHEDULE of RACES:

All times are Eastern Daylight Savings Time. It is intended that two morning races be sailed, lunch ashore, and then two races be sailed in the afternoon. Weather conditions may change this intended schedule. No more than 3 races will be sailed back to back without the competitors being sent to shore. It is intended that no more than 5 races will be sailed per day. Sufficient time each day will be provided for lunch. Three races must be completed to constitute a regatta.

Saturday 18 July, 2026

0900 hrs - Competitors Meeting ashore

0930 hrs - Harbour Signal - Competitors should sail to the race area. Race committee in position
4 short sound signals

1000 hrs - Warning signal first race

Lunch & races as per SYC Starter

Harbour Signal + 30 Minutes Warning signal of next race

Sunday 19 July, 2026

0900 hrs - Harbour Signal. Race committee in position 4 short sound signals

0930 hrs - Warning signal first race.

Other race to follow as per SYC Starter





NOTE: No race warning signal will be made after 1300 hrs



CLASS FLAG AND RACE WARNING FLAG – A Black Y on a lime green background

RACING AREA – The race committee will attempt to set a course such that the first boat will finish in approximately 45 minutes. The course chosen will be selected to optimize wind conditions to provide a challenging and interesting race.

THE START: The start line will be between the Blue flag on the committee boat and the Buoy.

Flags Used:

	Postponement. Races not started are postponed. Drop of flag and sounding ends postponement, warning signal to follow.	Two sounds
	OCS. (on Course Side) The Race committee will attempt to indicate boats that are OCS with the flag and a hail of the Boat Number.	
	Ashore: A notice to competitors has been posted. Afloat : Come within hail	
	Preparatory Signal.	One sound

	Class Flag.	One sound
	Shortened Course. (flag S) Displayed by support boat.	Two sounds
	Race Committee flag marks start and finish line	

THE FINISH: The finish line will be between the blue flag on the race committee boat and the buoy.

TIME LIMIT: Racing will be limited to 2 hours for the first boat to finish.

If the last boat/s to finish in a race is/are unduly delaying the start of another race, and/or such action by is determined by the RC to be in the best interest of the regatta, the RC will terminate the race and score those boats in the place they would have finished, based on the judgment by the RC, at the time the race is terminated. If the RC is unable to clearly judge the relative position of 2 or more boats, 2 or more boats will all be given the same better score. The scoring of a boat by the RC will not be grounds for Redress. This changes RRS 62.1(a)

A support boat will notify all boats of the shortening of the course by displaying Code Flag S, with two sounds, as the leading boat passes the mark, that then begins the new last leg of the course and ends at the RC Boat from the direction of the last mark. Code Flag S will be displayed, with additional two sounds, until all boats have passed. This changes RRS 32.2

PROTESTS: It is the expectation of the Race Committee that all competitors will abide by the RRS and will take the required penalties for infractions without necessitating a formal protest. However a protest committee of three will be formed, where required, drawn from knowledgeable competitors who are not witnesses or affected by the protest outcome. As this may be a challenge, the first course of action is strongly recommended.

Should competitors intend to protest they must notify the Committee boat on completion of the race and provide a written protest within 45 minutes of coming ashore. Protest Forms will be available ashore. Protest notices will be posted on the Notice board at the end of each day.

SCORING: Scoring for the Canadian National Y-Flyer Championship will be in accordance with the RRS art 90.3. Scores will be the sum of boats finishing scores with the throw out of the worst score after 6 or more races have been completed in the regatta. Individual race scores will be awarded as follows:

RAS – Rank as a starter. All competitors who sail in the vicinity of the starting line.

Starter – all competitors who start correctly.

Finisher – all competitors who are finished by the race committee. Scored as 1 point for first place and point score = the finish order of crossing the finish line.

DNF - Did Not Finish. A competitor who starts but does not finish the race. Score = Finishers + 1

OCS – On the Course Side – On the course of the starting line at the start of the race and uncorrected by returning and correctly sailing over the start line. Scored = number of RAS.

DSQ - Disqualified by the Race Committee for infringement of a racing rule. Scored = RAS + 1. If a competitor is given a finish position by the Race Committee and subsequently is awarded DSQ by the Protest Committee section of the Race Committee, all subsequent finishers are moved forward in the finish order.

DNC - Did Not Compete. The competitor did not RAS. Scored = # of all Regatta registrants.

Redress - A competitor whose race score is adjusted by the Protest Committee. The Protest Committee shall follow the guidance on Redress of the ISAF and indicate the method of scoring.

Breaking of Ties – In the event of a tie in the scoring at the conclusion of the racing, the competitor who beat the other competitor, or competitors, the most times, including any thrown out race scores, shall be awarded the better overall finish position. If a tie still exists, the results of the last race of the series shall govern. If a tie still exists, the last race sailed in which one or both of the tied competitors finished shall govern.

PFD. The Race Committee will not proscribe the wearing of personal flotation devices although this practice is recommended. The choice to wear or not wear a PFD is the competitor's responsibility alone.

RETIRING: Competitors who retire from a race should inform the race committee boat or safety boat.

DISCLAIMER OF LIABILITY: Competitors in this event are participating entirely at their own risk. See RRS 4, Decision to Race. Competitors agree that the race organizers (organizing authority, race committee, protest committee, host Fleet, will not be responsible for damage to any boat or other property or the injury to any competitor, including death, sustained as a result of participation in this event. Each competitor agrees that by participating in this event each competitor is deemed to have waived all claims against and released the race organizers from any and all liability associated with such competitor's participation in this event to the fullest extent permitted by law and is deemed to have warranted that he/she has obtained this same release of the race organizers by each crew member.

PRECEDENCE: In the event of a conflict between these Sailing Instructions and the Notice of Race, these Sailing Instructions shall have precedence. This changes to RRS 63.7.

COURSE DIAGRAMS

Course "A" Modified Olympic

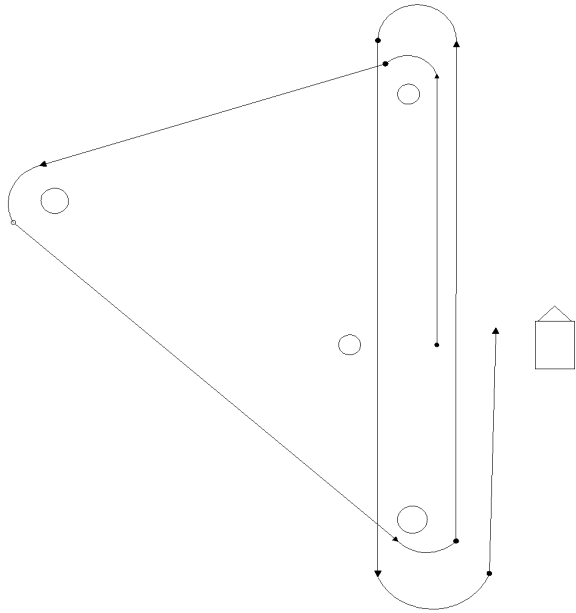

Course "B" Windward/Leeward

